

SmartZone-2 & -4

Residential & Light Commercial HVAC Zoning System up to 4 Zones

General Description

The SmartZone-2&4 residential and light commercial zone controllers provide reliable control of up to four (4) zones from a single forced-air HVAC system. The Zoning Panel includes an LED display with full text for status monitoring and diagnosis of the entire system and equipment. Each thermostat and equipment terminal has its own color-coded LED allowing for quick & easy diagnostics of thermostat and system calls. A supply air plenum temperature sensor is also included with each controller. This sensor allows constant monitoring of supply temperature. XCI's exclusive Electronic Limit Control™ (ELC) technology protects the system compressor or heat exchanger from potential issues associated with freeze-up and overheating. Fresh Air Control is also integrated into the SmartZone™ panel for improving Indoor Air Quality (IAQ). Pushbuttons allow for simple & easy adjustment of high and low cut-out limit temperatures, fresh air timing and thermostat type selection.

SmartZone-2 & -4 Control Board Features

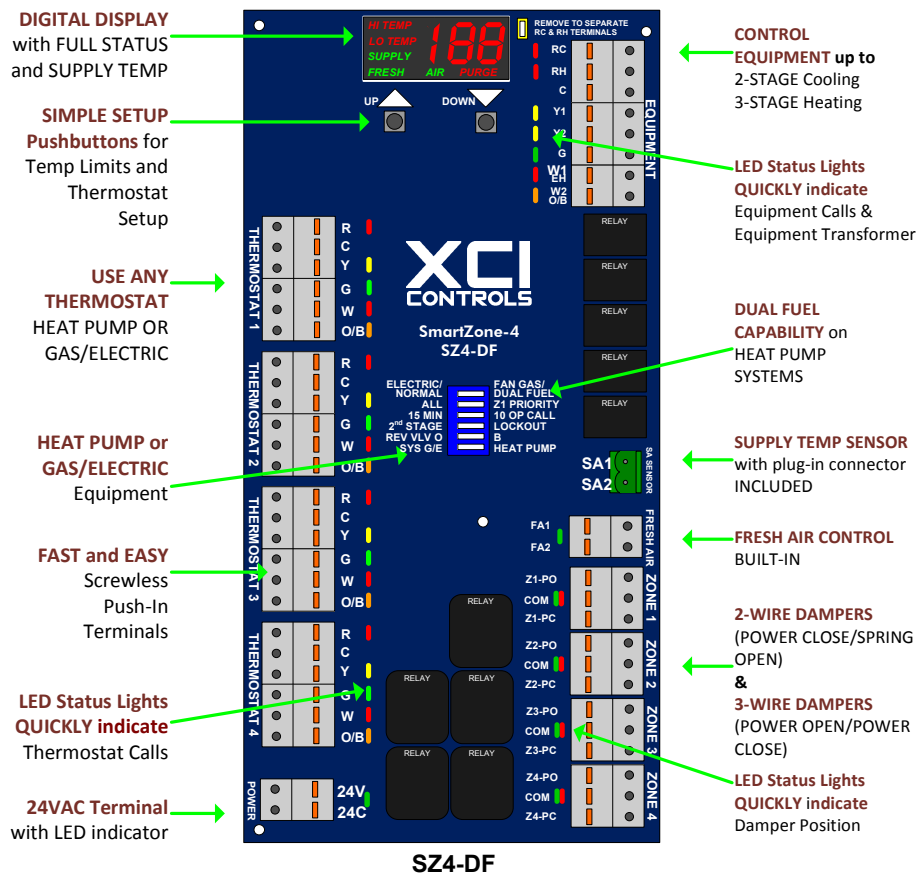

Flexible Installation

- Same Controller Handles Heat Pump, Dual Fuel and Gas/Electric Systems
- Supports up to 3-Stage Heating and 2-Stage Cooling Equipment
- Simple Pushbutton and Dipswitch Configuration
- Quick-Connect Screwless Terminals
- Innovative Enclosure Design with Multiple Wiring & Mounting Options

Simple Service

- Monitor Entire System from SmartZone Panel, including Supply Air Temp, Cut-Out, Purge and Fresh Air Conditions
- Color Coded Diagnostic LED Indicators for Each Thermostat Call
- Two-Color LED Indicators for Each Damper Position
- Electronic Limit Control™ (ELC) Protects Compressor and Heat Exchanger

Easy Operation

- Mix & Match Standard Gas/Electric and Heat Pump Thermostats
- Built-In Adjustable Fresh Air Damper Control from 0 to 60 Minutes per Hour
- Intelligent Staging Based on Supply Air Temperature and Time
- Automatic Changeover for Maximum Comfort
- Pushbutton ELC™ for Adjustable Temperature Cut-Outs

Convenient Customer Features

- Customer Never Needs to Use the Control Panel
- Selectable Zone-1 Priority for More Customer Control
- Enable Emergency Heat from Heat Pump Thermostat
- Zone-Specific Ventilation Mode; Energize Fan from Any Thermostat
- Superior 5-Year Limited Factory Warranty

SPECIFICATIONS

POWER	SZ2 or SZ4	10VA MAX (375 mA @ 24VAC)
	SYSTEM	10VA + Thermostat (3VA) + Damper (3 to 10 VA) = Total Transformer Size
	PROTECTION	Integrated Electronic Auto-Reset Fused links (Field supplied transformer should also be fused)
OUTPUTS	EQUIPMENT	2 AMP @ 24VAC Contact Rating RH – 24VAC HOT from Heating Transformer on Equipment (RED) RC – 24VAC HOT from Cooling Transformer on Equipment (RED) C – 24VAC COMMON from Transformer on Equipment (none) Y1 – 1 st Stage Compressor (YELLOW) Y2 – 2 nd Stage Compressor (YELLOW) G – Fan (GREEN) W1/EH – 1 st Stage Heat OR Emergency Heat (RED) W2/OB – 2 nd Stage Heat OR Reversing Valve (RED)
	DAMPERS	10 AMP @ 24VAC Contact Rating (40VA) Power-Close / Spring-Open Dampers (10VA) Power-Open / Spring-Close Dampers (10VA) Power-Open / Power-Close Dampers (3VA)
INPUTS	THERMOSTAT	LABEL – DESCRIPTION (LED COLOR) R – 24VAC HOT (RED) C – Common (NONE) Y – Compressor (YELLOW) G – Fan (GREEN) W – Heat OR Emergency Heat (RED) O/B – Reversing Valve (ORANGE)
	TEMPERATURE	10K Type III Thermistor SA Sensor – Supply Air Temperature Sensor (Provided with SZ2 or SZ4)
CONFIGURATION	DIP SWITCHES	Gas/Electric or Heat Pump Reversing Valve O or B Allow 2 nd Stage ALWAYS or ONLY with more than 1 Zone Opposing Call Time 15 Minutes or 10 Minutes Priority for ALL Zones or for Zone ONE Fan Electric / Normal or Fan Gas / Dual Fuel for Heat Pump
	DISPLAY MENU	Supply Air Temperature Purge Status Low Temp / High Temp Cutouts Fresh Air Status and Time

Clear Cover Plastic Enclosure

Included with SmartZone

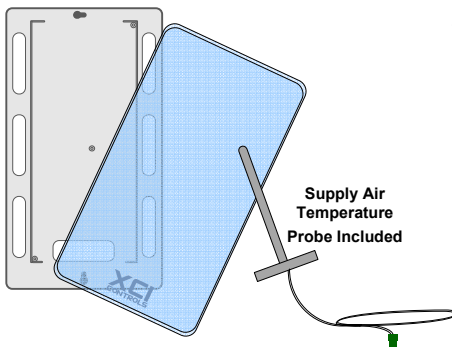

SmartZone Dampers

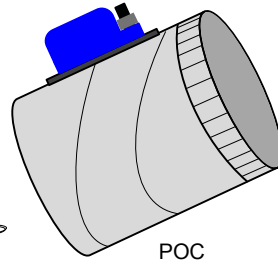

TrueTouch Thermostats

Optional

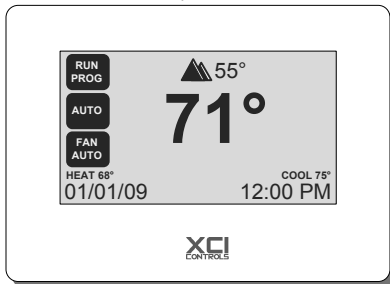

TSZ-1 w/ Wireless Outdoor Temp Sensor

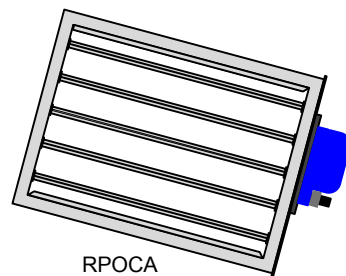

Part Numbers

- **SZ2-DF**
SmartZone-2 (2-Zones) with standard enclosure
- **SZ4-DF**
SmartZone-4 (4 Zones) with standard enclosure
- **SZ2-DF-SP**
SmartZone-2 (2-Zones) with SmartPanel bracket
- **SZ4-DF-SP**
SmartZone-4 (4 Zones) with SmartPanel bracket
- **SZ2-KIT**
SmartZone-2 (2-Zone) Kit including 2 thermostats, static pressure controller, and 24VAC transformer
- **SZ3-KIT**
SmartZone-4 (3-Zone) Kit including 3 thermostats, static pressure controller, and 24VAC transformer
- **SZ4-KIT**
SmartZone-4 (4-Zone) Kit including 4 thermostats, static pressure controller, and 24VAC transformer

Other References

- **SmartZone-2&4 System Manual** for a full guide to this product
- **SmartZone-2&4 Quick-Start Guide** for a step by step process for installation
- **SmartZone-2&4 Quick-Reference Sheet** for a brief overview of this product answering most installation questions
- References available at xcicontrols.com or by calling toll free 866-924-4822

Accessories

Dampers

- Round Power-Close/Spring-Open [SZD]
- Round Power-Open/Power-Close [POC]
- Rectangular Power-Open/Power-Close [RPOCA]
- Static Pressure Controlled Bypass [SPC]
- Barometric Bypass [BBD]
- Fresh Air [FAD]

Thermostats

- **TrueTouch** touch-screen thermostats [TSZ-1, TSZ-2, TSH-2]
- **NetworkThermostats** for PC based control

Included with SmartZone

- **Plastic Enclosure or SmartPanel Bracket** for multiple mounting options
- **Supply Air Temperature Sensor Probe** with pluggable connector
- **SmartZone-2&4 Quick-Start Guide**
- **Superior 5-Year Limited Factory Warranty**