

## SmartZonePLUS RZ1 & RZ4

## Commercial & Residential HVAC Expandable Zoning System up to 33 Zones

### General Description

The **SmartZonePLUS™** family of residential and light commercial zone controllers provide reliable control of up to thirty-three (33) zones from a single forced-air HVAC system. The RZ4 expander module includes an LED display with full text for status monitoring and diagnosis of each zone as well as equipment mode. The RZ4 is fully communicating with the equipment controller (EC1). This allows each RZ4 to be mounted near the zones which it serves. This requires less stat wire and damper wire on large projects. On large projects, SmartPanel™ allows stowaway installation with easy wiring and locking door (see SmartPanel™ Spec Sheet). Heavy-duty damper relays allow multiple dampers to be connected (parallel daisychain) when several dampers are required on each zone. Permanent Comfort/Economy mode can be applied to all four zones or individually applied Comfort/Economy mode can be operated through each thermostat for true utility savings.

### Expandable Installation

- UP to 33 Zones
- Same Controller Handles Heat Pump, Dual Fuel (NO Dual Fuel Kit required) and Gas/Electric Systems
- Supports up to 3-Stage Heating and 2-Stage Cooling Equipment
- Configurable Balance points and Fresh Air Temp limits
- Humidity Control from Zone 1 Thermostat
- Simple Pushbutton and Dipswitch Configuration
- Quick-Connect Screwless Terminals
- Innovative Enclosure Design with Multiple Wiring & Mounting Options

### Simple Service

- Monitor System Status from every SmartZonePLUS RZ Panel, including Equipment Mode, Heat, Cool, Emergency Heat, Delay, Purge, Humidity, Call Acknowledgement and Comm status
- Color Coded Diagnostic LED Indicators for Each Thermostat Call
- Two-Color LED Indicators for Each Damper Position

### SmartZonePLUS RZ4 4-Zone Expander

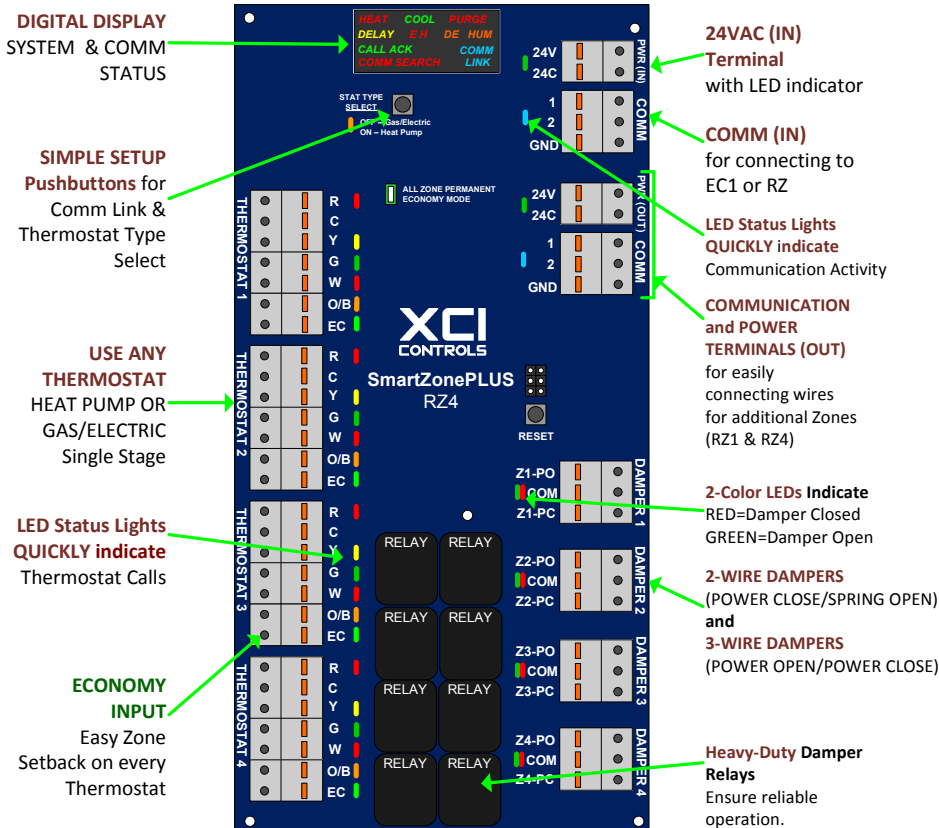

SmartZonePLUS-RZ4 (RZ1 also available)

### Easy Operation

- Link communications to EC1 with one button push
- Set thermostat type for entire RZ board with a 2 second button push
- Intelligent Staging Based on Supply Air Temperature and Time or Zone 1 thermostat.
- Automatic Changeover for Maximum Comfort
- Electronic Limit Control™ (ELC) Protects Compressor and Heat Exchanger

### Convenient Customer Features

- Unique ECOMOMY Mode for optimum efficiency
- Customer Never Needs to Use the Control Panel
- Selectable Zone-1 Priority for More Customer Control
- Enable Emergency Heat from Heat Pump Thermostat
- Superior 5-Year Limited Factory Warranty

### SPECIFICATIONS

POWER	RZ1	10VA MAX (275 mA @ 24VAC)
	RZ4	14VA MAX (350 mA @ 24VAC)
	SYSTEM	RZ (14 or 10 VA) + Thermostat (3VA) + Damper (3 to 10 VA) = Total Transformer Size
	PROTECTION	Integrated Electronic Auto-Reset Fused links (Field supplied transformer should also be fused)
OUTPUTS	COMMUNICATION	COMM – 3 wire reliable communications to EC1 (BLUE) [Use Cat5 Cable ONLY]
	DAMPERS	<b>10 AMP @ 24VAC Contact Rating (40VA)</b> Power-Close / Spring-Open Dampers (10VA) Power-Open / Spring-Close Dampers (10VA) Power-Open / Power-Close Dampers (3VA)
INPUTS	THERMOSTAT	<u>LABEL – DESCRIPTION (LED COLOR)</u> R – 24VAC HOT (RED) C – Common (NONE) Y – Compressor (YELLOW) G – Fan (GREEN) W – Heating OR Emergency Heat (RED) OB – Reversing Valve (ORANGE)
	ECONOMY	EC – Single Zone Economy Mode (GREEN)
	COMMUNICATION	COMM – 3 wire reliable communications to EC1 (BLUE) [Use Cat5 Cable ONLY]
CONFIG	PUSHBUTTONS / JUMPER	
	Initialize COMM with EC1 Set Thermostat Type Reset Jumper to set Permanente Economy Zone(s)	DISPLAY MENU HEAT COOL PURGE DELAY Emergency Heat Humidify / Dehumidify COMM SEARCH COMM LINK

### Part Numbers

- **EC1**  
SmartZonePLUS-EC1 (Equipment Controller)
- **EC1-SP**  
SmartZonePLUS-EC1 w/ SmartPanel Bracket
- **RZ4**  
SmartZonePLUS-RZ4 (4-Zone Expander)
- **RZ4-SP**  
SmartZonePLUS-RZ4 w/ SmartPanel Bracket
- **RZ1**  
SmartZonePLUS-RZ1 (1-Zone Expander)
- **RZ1-SP**  
SmartZonePLUS-RZ1 w/ SmartPanel Bracket

### Other References

- **SmartZonePLUS System Manual** for a full guide to this product
- **SmartZonePLUS Quick-Start Guide** for a step by step process for installation
- **SmartZonePLUS EC1 Quick-Reference & RZ Quick-Reference** for a brief overview of this product answering most installation questions
- References available at [xcicontrols.com](http://xcicontrols.com) or by calling toll free 866-924-4822

#### Clear Cover Plastic Enclosure

Included with SmartZonePLUS RZ4

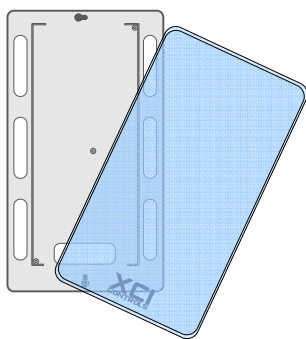

Included with SmartZonePLUS RZ1

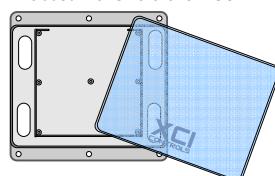

#### SmartZone Dampers

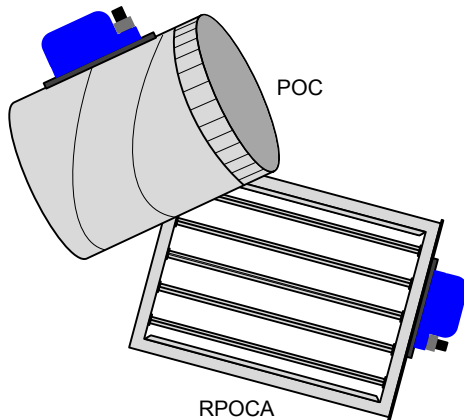

#### TrueTouch Thermostats

Optional

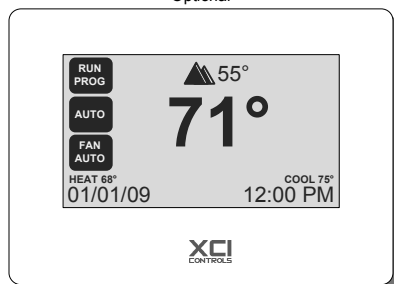

TSZ-1 w/ Wireless Outdoor Temp Sensor

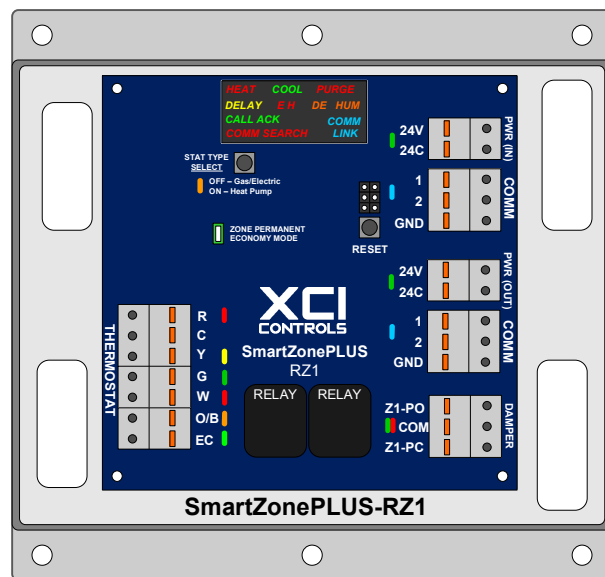

#### Included with RZ1 & RZ4

- Plastic Enclosure or SmartPanel Bracket for multiple mounting options
- Superior 5-Year Limited Factory Warranty