

SmartZonePLUS EC1

Commercial & Residential HVAC Expandable Zoning System up to 33 Zones

General Description

The **SmartZonePLUS™** family of residential and light commercial zone controllers provides reliable control of up to thirty-three (33) zones from a single forced-air HVAC system. All electronic boards include LED displays with full text for status monitoring and diagnosis of the zoning system and equipment. Each thermostat, equipment terminal and zone damper terminal has color-coded LEDs for easy monitoring of all thermostats and system status. A supply air plenum temperature sensor is included with each EC1 (Equipment Controller) for constant monitoring of supply temperature. XCI's exclusive Electronic Limit Control™ (ELC) technology protects the system compressor or heat exchanger from potential issues associated with over-cooling and over-heating. Fresh air control is also integrated into the **SmartZonePLUS™** EC1 controller. Indoor air quality is improved as pushbuttons allow for quick and easy adjustment of high and low cut-out limit fresh air temperatures as well as fresh air timing. XCI's unique **ECONOMY** mode allows the SmartZonePLUS system to be configured for maximum efficiency.

Flexible Installation

- UP to 33 Zones
- Same Controller Handles Heat Pump, Dual Fuel (NO Dual Fuel Kit required) and Gas/Electric Systems
- Supports up to 3-Stage Heating and 2-Stage Cooling Equipment
- Configurable Balance points and Fresh Air Temp limits
- Humidity Control from Zone 1 Thermostat
- Simple Pushbutton and Dipswitch Configuration
- Quick-Connect Screwless Terminals
- Innovative Enclosure Design with Multiple Wiring & Mounting Options

Simple Service

- Monitor Entire System from SmartZonePLUS EC1 Panel, including Supply Air Temp, Cut-Out, Purge and Fresh Air Conditions, Equipment Mode
- Color Coded Diagnostic LED Indicators for Each Thermostat Call
- Two-Color LED Indicators for Each Damper Position
- Electronic Limit Control™ (ELC) Protects Compressor and Heat Exchanger

SmartZonePLUS EC1 Equipment Control Board

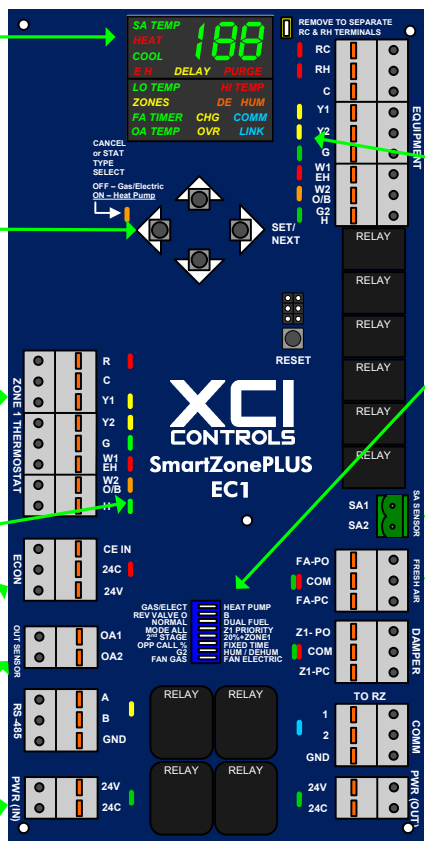
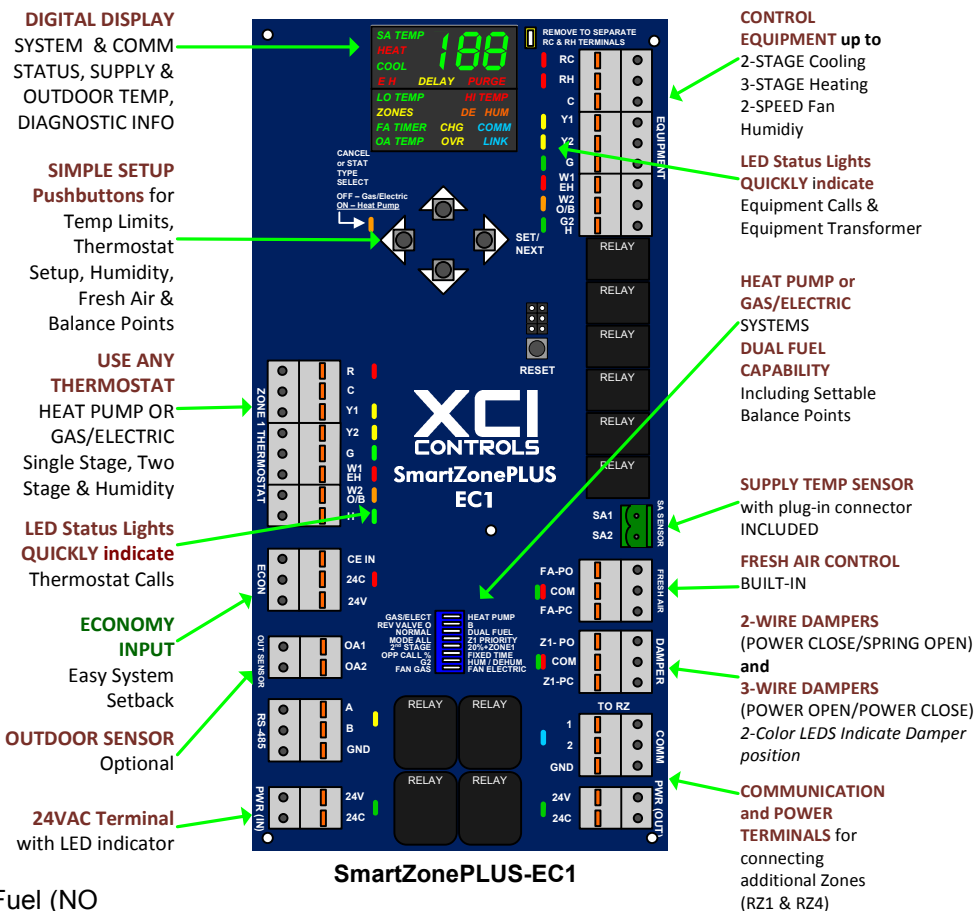

SmartZonePLUS-EC1

Easy Operation

- Gas/Electric and Heat Pump Thermostats
- Built-In Adjustable Fresh Air Damper Control from 0 to 60 Minutes per Hour with Outdoor temperature limits
- Intelligent Staging Based on Supply Air Temperature and Time or Zone 1 thermostat.
- Automatic Changeover for Maximum Comfort
- Pushbutton ELC™ for Adjustable Temperature Cut-Outs
- Monitor # of cool calls, # of heat calls, # of total zones, minutes before changeover, outdoor air temp

Convenient Customer Features

- Unique **ECONOMY** Mode for optimum efficiency
- Customer Never Needs to Use the Control Panel
- Selectable Zone-1 Priority for More Customer Control
- Enable Emergency Heat from Heat Pump Thermostat
- Superior 5-Year Limited Factory Warranty

SPECIFICATIONS

POWER	EC1	14VA MAX (350 mA @ 24VAC)
	SYSTEM	14VA + Thermostat (3VA) + Damper (3 to 10 VA) = Total Transformer Size
	PROTECTION	Integrated Electronic Auto-Reset Fused links (Field supplied transformer should also be fused)
OUTPUTS	EQUIPMENT	2 AMP @ 24VAC Contact Rating RH – 24VAC HOT from Heating Transformer on Equipment (RED) RC – 24VAC HOT from Cooling Transformer on Equipment (RED) C – 24VAC COMMON from Transformer on Equipment (none) Y1 – 1 st Stage Compressor (YELLOW) Y2 – 2 nd Stage Compressor (YELLOW) G – Fan (GREEN) W1/EH – 1 st Stage Heat OR Emergency Heat (RED) W2/OB – 2 nd Stage Heat OR Reversing Valve (RED) G2/H – High Speed Fan OR Humidity Control (ORANGE)
	DAMPERS	10 AMP @ 24VAC Contact Rating (40VA) Power-Close / Spring-Open Dampers (10VA) Power-Open / Spring-Close Dampers (10VA) Power-Open / Power-Close Dampers (3VA)
	COMMUNICATION	COMM – 3 wire reliable communications to EC1 (BLUE) [Use Cat5 Cable ONLY] RS485 – External RS485 port for PC or automation system interface
INPUTS	THERMOSTAT	<u>LABEL – DESCRIPTION (LED COLOR)</u> R – 24VAC HOT (RED) C – Common (NONE) Y1 – 1 st Stage Compressor (YELLOW) Y2 – 2 nd Stage Compressor (YELLOW) G – Fan (GREEN) W1/EH – 1 st Stage Heating OR Emergency Heat (RED) W2/O/B – 2 nd Stage Heating OR Reversing Valve (ORANGE) H – Humidity Control (Orange)
	ECONOMY	CE INPUT – System Wide Economy Mode (RED)
	TEMPERATURE	10K Type III Thermistor SA Sensor – Supply Air Temperature Sensor (Provided with EC1) OA Sensor – Outdoor Air Temperature Sensor (Optional)
CONFIGURATION	DIP SWITCHES	Gas/Electric or Heat Pump Reversing Valve O or B Normal or Dual Fuel for Heat Pump Priority for ALL Zones or for Zone ONE Allow 2 nd Stage ALWAYS or ONLY with 20% Calling Zones Opposing Call Time Dynamic % Changeover or Fixed time Variable Speed Fan Control or Humidity Control Fan Gas (with plenum switch) or Fan Electric (with EC1)
	DISPLAY MENU	Supply Air Temperature Outdoor Temperature Zones calling for Heat/Cool Total Zones Change Over time Low Temp / High Temp Cutouts Humidify / Dehumidify Fresh Air

Clear Cover Plastic Enclosure

Included with SmartZonePLUS EC1

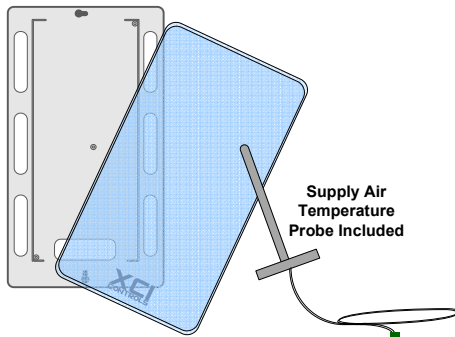

TrueTouch Thermostats

Optional

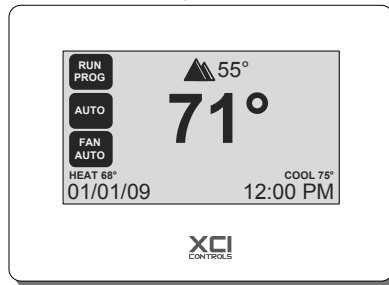

TSZ-2 w/ Wireless Outdoor Temp Sensor

SmartZone Dampers

Outdoor Temperature

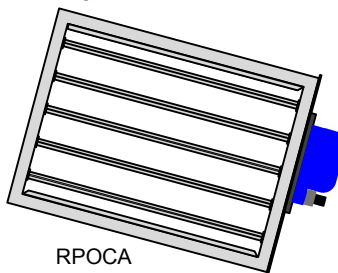
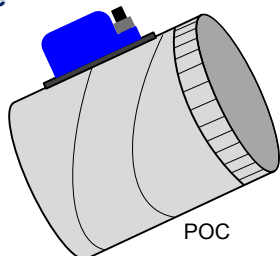
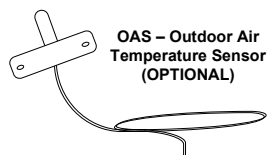

Part Numbers

- **EC1**
SmartZonePLUS-EC1 (Equipment Controller)
- **EC1-SP**
SmartZonePLUS-EC1 w/ SmartPanel Bracket
- **RZ4**
SmartZonePLUS-RZ4 (4-Zone Expander)
- **RZ4-SP**
SmartZonePLUS-RZ4 w/ SmartPanel Bracket
- **RZ1**
SmartZonePLUS-RZ1 (1-Zone Expander)
- **RZ1-SP**
SmartZonePLUS-RZ1 w/ SmartPanel Bracket

Other References

- **SmartZonePLUS System Manual** for a full guide to this product
- **SmartZonePLUS Quick-Start Guide** for a step by step process for installation
- **SmartZonePLUS EC1 Quick-Reference & RZ Quick-Reference** for a brief overview of this product answering most installation questions
- References available at xcicontrols.com or by calling toll free 866-924-4822

Accessories

Sensors

- SmartZonePLUS-Outdoor Temperature Sensor [OAS]

Dampers

- Round Power-Close/Spring-Open [SZD]
- Round Power-Open/Power-Close [POC]
- Rectangular Power-Open/Power-Close [RPOCA]
- Static Pressure Controlled Bypass [SPC]
- Barometric Bypass [BBB]
- Fresh Air [FAD]

Thermostats

- **TrueTouch** touch-screen thermostats [TSZ-1, TSZ-2, TSH-2]
- **NetworkThermostats** for PC based control

Included with EC1

- Plastic Enclosure or SmartPanel Bracket for multiple mounting options
- Supply Air Temperature Sensor Probe with pluggable connector
- **SmartZonePLUS EC1 & RZ Quick-Reference**
- **Superior 5-Year Limited Factory Warranty**